

Conversion of Laser Rayboxes for 3V power supply/battery operation

- 1 Pop the top cover of the laser off by depressing the switch and pulling the two sections apart. This is easiest if you lever from the back.
- 2 Drill a 6mm hole in the rear of the the laser top housing (Blue or yellow section)
- 3 Fit the jack socket into the drilled hole.
- 4 Cut two 50mm lengths of thin insulated hook up wire. Strip and tin both ends.
- 5 Aim the laser away from you and identify the battery contacts. The right hand contact will have a green or red wire coming from the switch, the left hand one will have a black wire.
- 6 Desolder the red/green wire from the right hand battery contact, and solder to jack socket point C. Solder one of the new wires between jack socket point B and the right hand battery contact.
- 7 Solder the second new wire between the left hand battery contact and solder it to jack socket point A. Do not remove the original wiring to the left hand battery contact. There should now be two wires connected to the left hand contact. .
- 8 Reassemble the case.
- 9 Using a plug-top power supply set to **3V dc** and fitted with a 3.5mm jack plug wired with the plug tip positive, plug into the laser and switch on – the laser should operate. Please be aware that there is a warm up time of up to 5 minutes before the laser operates at full power.
- 10 The laser will now operate on battery power. Plugging the jack plug in switches from battery to power supply operation.
- 11 **N.B. Ensure that 3V only is used. Higher voltage will destroy the laser element.**

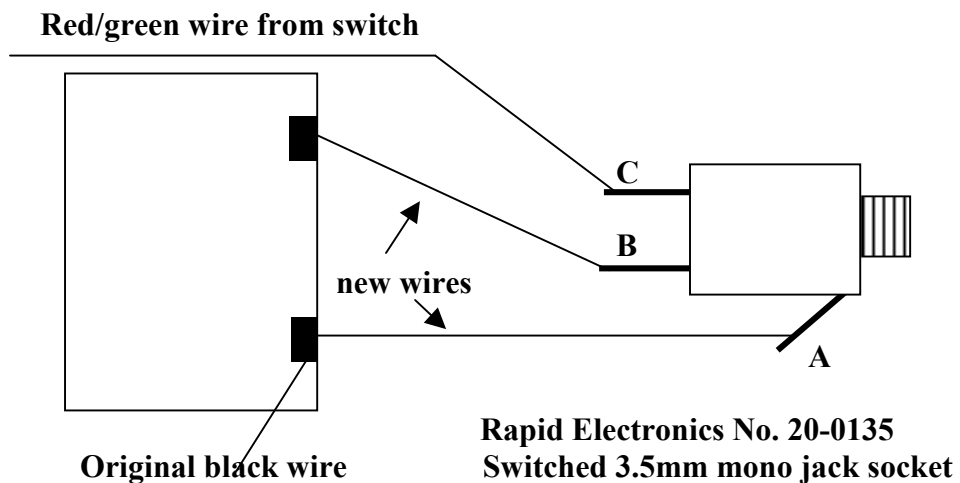

**Phil Walsh
Electrosound
01376 340506**