

# National Grid Simulation.

## High Voltage Power Lines Why Bother?

The National Grid is familiar to us all. Just look around and you will see pylons with cables strung between them. Electricity used in our homes is at about 240V. Why not just transmit it at this voltage, rather than the higher voltages ranging from 11,000V (11kV) to 400,000V (400kV), commonly used on overhead power lines?

The answer is energy loss due to the heating effect of current in the power lines. This is much greater at low voltages, when the current must be high to transmit enough power. Hence the electricity suppliers transport their electricity around the country at very high voltages, in order to reduce the current, and hence the energy loss.

Typically a power station generates at 25kV. This is transformed up to 275kV/400kV, sent along the cables and then transformed down again near to where it is to be used.

It is obviously not practical, or safe, to demonstrate at these voltages so the following is a “scaled down” version, which demonstrates the principle.

**PLEASE NOTE. UNDER NO CIRCUMSTANCES SHOULD THE RESISTANCE WIRES BE CONNECTED BETWEEN THE 12V SOCKET AND THE 240V SOCKET. THIS COULD CAUSE DAMAGE TO THE UNITS.**

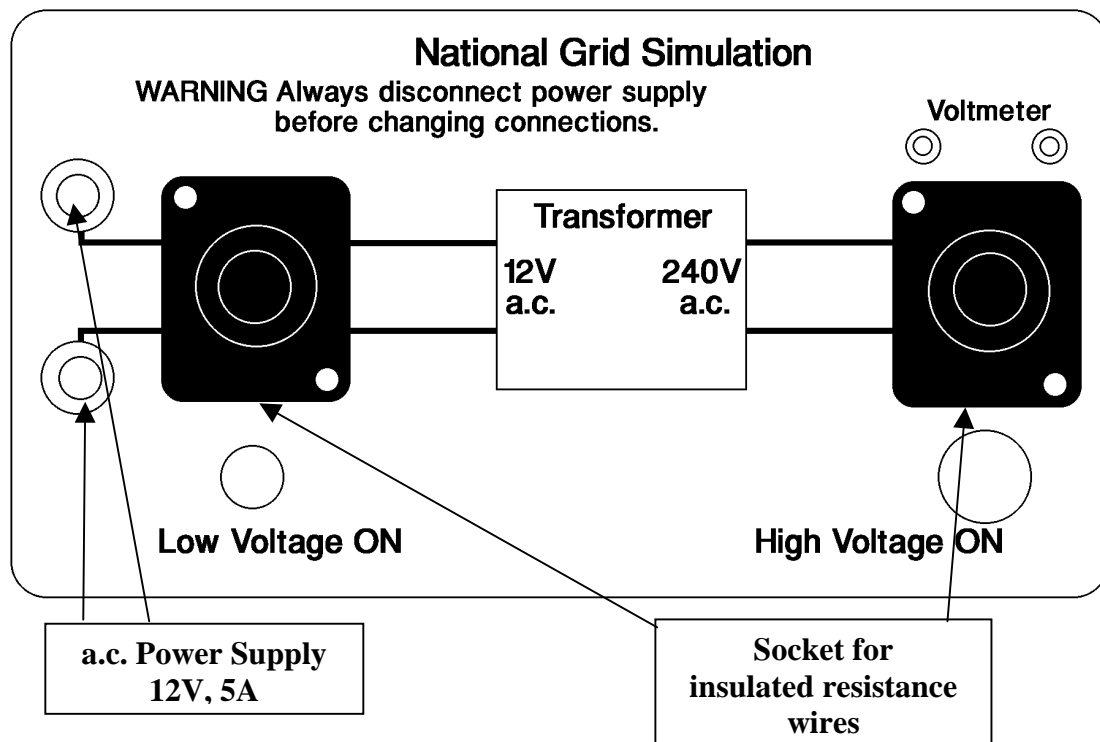

The apparatus uses two identical boxes, connected together using carefully chosen resistance wires, representing the power line. Each box contains a transformer, voltage indicators and sockets. Inside, the low voltage wiring is yellow and the high voltage wiring is red. For correct operation, it is essential to use two 12V, 24W lamps, which are supplied with holders. These lamps and power supply (not supplied) should be connected together with standard leads fitted with 4mm plugs.

**If 12 V is used as the input voltage, voltage should not be measured at the red sockets unless a high impedance meter with only two sockets, equipped with GS 38-compliant probes is used. Teachers wishing to show how the voltage is stepped up and who do not have access to such equipment should reduce the supply voltage to 3 V and use 3.5 V MES bulbs.**

## **IMPORTANT**

**Ensure all connections have been made correctly, before turning on the power supply. Switch off before disconnecting any leads**

**The power supply unit must be capable of delivering 12 volts a.c. at 5A. Never use a d.c. power supply.**

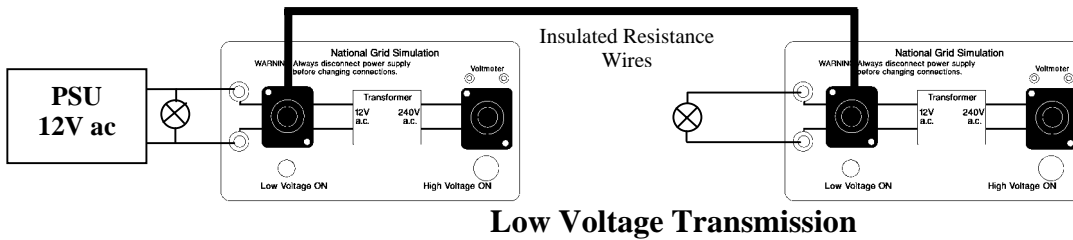

**Low Voltage Transmission**

The demonstration boxes are connected as follows:

- Plug the resistance wires into the 12V socket on each unit.  
The resistance wire plugs should be inserted into the relevant socket and then the blue section turned clockwise to lock. To remove pull the grey collar up and twist anti clockwise.
- **Dangerous. Do not poke bare wires into these connectors.**
- Switch on the low voltage power supply and observe the 24W lamps

The left-hand lamp is fed directly from the power supply and glows normally. However the right hand lamp is being powered via the resistance wires (a mock up of long overhead transmission cables) and is very dim. This is the equivalent of transmitting at mains voltage. It should be noted that the resistance wires start to get hot – that is where a lot of the energy is being lost. Note also that the neon on the receiving box does not glow. The transformer is not receiving enough low voltage to transform up to the neon's striking voltage (about 90V).

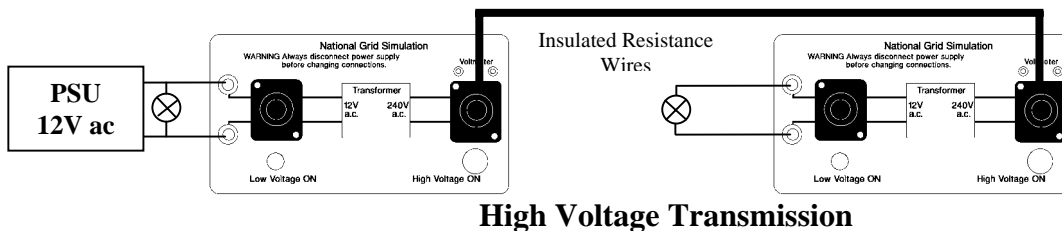

**High Voltage Transmission**

- Now switch off and plug the resistance wires into the 240V socket on each unit
- Switch on the low voltage power supply and observe the 24W lamps

This is the equivalent of transmitting at high voltage.

The low voltage (12V) is transformed up to high voltage (240V), sent along the transmission lines, then transformed back down to low voltage (12V) to be used.

Assuming that, for the transformers, Power in = Power out (it never is, due to resistive losses in the windings, magnetostriction etc), then, because the transmission voltage is now 20 times larger, the current is 20 times smaller. The energy loss in the power lines is, therefore, 400 times lower (energy loss is proportional to current squared).

The small red sockets, above the 240V socket, are designed to be used with insulated multimeter probes, so that the high voltage may be shown. Under no circumstances should bare wire or standard 2mm plugs be used.

**CAUTION 240V is present at the red sockets and great care should be taken.**

Do not attempt to repair the resistance wires should they break, this is potentially dangerous. Simply send them back to us and we will refurbish them for a nominal charge.

The lamps used are 12V, 24W axial filament SBC type and are available from us.